

Digital Pulse Processor and Power Supply

PX4

Features

- Single unit compatible with all Amptek XR100 Si and CdTe detectors, includes:
 - ❖ Shaping amplifier using the DP4 digital pulse processing technology
 - ❖ Integrated multichannel analyzer
 - ❖ Power supplies
- Can be used with detectors from other manufacturers
- Trapezoidal shaping with wide range of shaping time settings to optimize performance
- High count rate capability with excellent baseline stability, throughput, and pile-up rejection
- Up to 8 k output MCA channels
- USB interface to personal computer, with software to support instrument control, data acquisition, and analysis
- Oscilloscope mode available - DAC output for pulse monitoring and adjustment

Power

- High voltage bias adjustable 100V to 1.5 kV
- Thermoelectric cooler with feedback
- Operates from AC supply

Overview

The Amptek PX4 is an interface between Amptek's XR100 series of X-ray and γ -ray detectors and a personal computer with data acquisition, control, and analysis software. The PX4 includes three major components: (1) a shaping amplifier, based on a state of the art, high performance, low power DP4 digital pulse processor, (2) a multichannel analyzer, and (3) power supplies. It replaces both the previous generation PX2 shaping amplifier and power supply and the separate MCA.

The pulse processing and MCA function of the PX4 are based on Amptek's DP4 digital pulse processor. The PX4 offers several performance advantages over traditional analog systems, including higher energy resolution, reduced ballistic deficit, higher throughput, better pile-up rejection, enhanced stability, and the ability to adjust shaping time parameters over a wide range to optimize performance. The PX4 includes a USB interface. The power supply portion of the PX4 provides all of the power necessary for the detector, preamplifier, and the PX4.

The PX4 offers several advantages over the previous generation PX2: (1) a single unit interfaces with all XR100 variants; (2) many parameters may be adjusted to optimize performance, such as shaping time constant and HV bias; (3) the pulse processor offers enhanced baseline stability, throughput, pile-up rejection, and Rise Time Discrimination (RTD); and (4) the MCA is integrated with the complete system.



FRONT



BACK

Photograph of the front and back of the PX4,

Physical

- Low Power: 2 W typical
- Small Size: 6.5 x 5.5 x 1.5 inches
165 x 135 x 40 mm
- Light Weight: 1.6 lbs/750 g

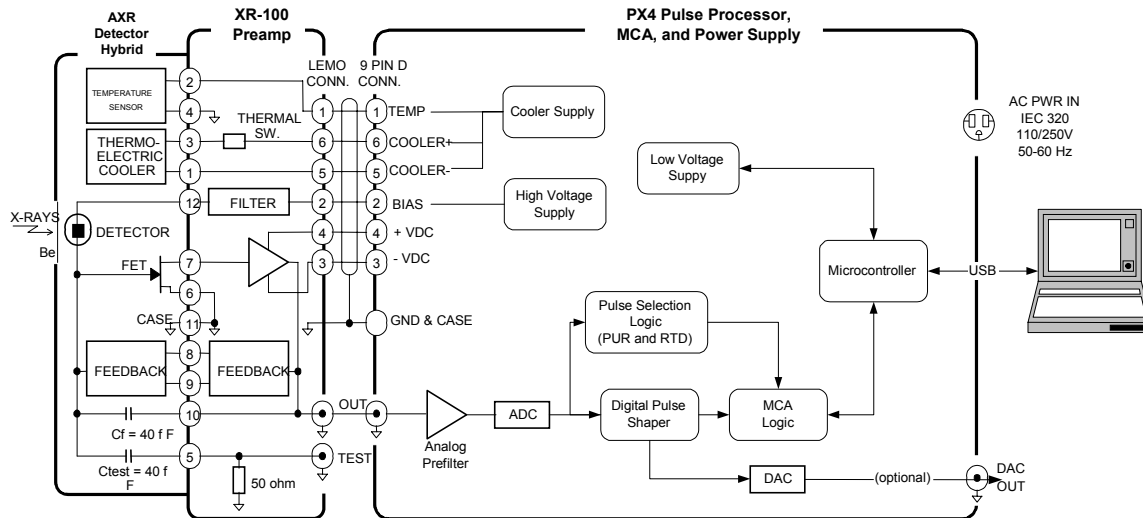

Figure 1. Block diagram of the PX4 in a complete system.

The signal input to the PX4 is the preamplifier output. The PX4 digitizes the preamplifier output, applies real-time digital processing to the signal, detects the peak amplitude (digitally), and bins this value in its histogramming memory, generating an energy spectrum. The use of digital signal processing offers several important performance advantages compared to previous systems. The spectrum is then transmitted over the PX4's USB interface to the user's computer. The PX4 hardware is controlled over the USB interface, permitting the user not only to start and stop acquisition but to select shaping times, select the HV bias, etc.

Specifications

Gain Settings: 28 user selectable gain settings from x4 to x550. Fine gain is adjustable between 0.75 and 1.25.

Pulse Shape: Trapezoidal. A semi-gaussian amplifier with shaping time τ has a peaking time of 2.2τ and is comparable in performance with the trapezoidal shape of the same peaking time.

Peaking and Flat Top Times: Twenty-four programmable peaking times between 0.8 and 102 μsec . For each peak time, sixteen flat top durations are available, $> 0.2 \mu\text{sec}$

Rise Time Discriminator (RTD): The digital pulse processor can be programmed to select input pulses based on their rise time properties.

Throughput: The pulse processing electronics have a cycle time of 1 μsec . With a peaking time of 0.8 μsec , a 1MHz periodic signal can be acquired. Dead time is 1.25 x peaking time.

Pile-Up Reject: Pulses separated by more than the fast channel resolving time, 600 nsec, and less than 1.25 x peaking time are rejected.

Number of channels: Commandable to 256, 512, 1 k, 2 k, 4 k or 8 k channels.

Connections

Analog Input (BNC): The analog input accepts pulses from the XR100 or any other detector with preamplifier reset or resistive feedback.

XR100 Power (6 pin LEMO): Provides power to preamp and detector. Includes HV bias, thermoelectric cooler power, and preamp power.

Serial Interface (USB): Standard USB interface and RS-232 interface to personal computer. Used for data acquisition and hardware control.

DAC Output (BNC): This output is used in oscilloscope mode, to view the shaped pulse and other diagnostic signals. Range: 0 to 1 V.

Input Power: 5 VDC (500 mA max) via power jack. It mates with a center positive 5.5 mm x 2.1 mm Power Plug.

For further technical specifications see our web site: www.amptek.com